

DORMER  PRAMET

СНЯТИЕ ГРАТА

2020



ОСОБЕННОСТИ И ПРЕИМУЩЕСТВА

 4

НАВИГАТОР

 9

ПЛАСТИНЫ

 10

КОЛЬЦЕВЫЕ ПЛАСТИНЫ

 16

ДЕРЖАВКИ

 18

ТЕХНИЧЕСКАЯ ЧАСТЬ

 21





СНЯТИЕ ГРАТА

ИНСТРУМЕНТ ДЛЯ СНЯТИЯ ГРАТА СО СВАРНЫХ ШВОВ

Мы предлагаем широкий ассортимент инструмента для зачистки швов свариваемых труб, который включает твердосплавные пластины с покрытием для работы при экстремально высоких температурах. Геометрия режущей кромки обеспечивает превосходное качество поверхности трубы и повышает срок службы инструмента.

В ассортимент были добавлены новые позитивные пластины для наружной обработки труб, новые размеры пластин и колец, а также подкладные пластины.

НАШЕ ПРЕДЛОЖЕНИЕ

- Пластины с разными конструкциями и радиусами для снятия наружного облоя сварного шва
- Кольцевые пластины разных размеров для снятия внутреннего облоя сварного шва
- Державки для снятия наружного облоя сварного шва

ПРЕИМУЩЕСТВА

- **Высокое качество поверхности** благодаря точности режущей кромки
- **Увеличенный срок службы инструмента** за счет использования сплавов, устойчивых к высокой температуре и выкрашиванию
- **Универсальность:** пластины из сплавов 6640 и T9335
- **Надежность:** стабильная фиксация предотвращает вибрацию пластин

ПЛАСТИНЫ



SNMX 15, 19, 25

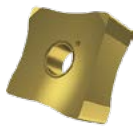

SNMX 2512, 1507

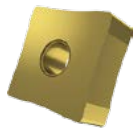

SNMA 1506, 2509

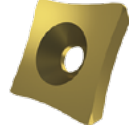

SPUB



LDGN



PSR

НОВЫЕ ПЛАСТИНЫ

NEW

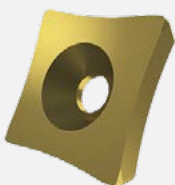

SPUB 19

- Односторонние позитивные пластины с задним углом 11°
- Четыре режущие кромки

NEW

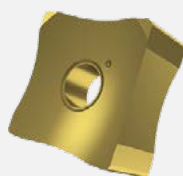

SNMX 1507

- Двухсторонние негативные пластины
- Восемь режущих кромок и вогнутая передняя поверхность

NEW

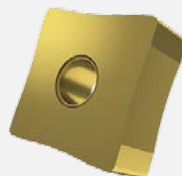

SNMA 1506

- Двухсторонние негативные пластины
- Восемь режущих кромок и плоская передняя поверхность

NEW

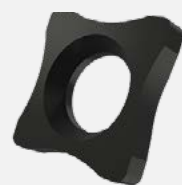

SNU

- Подкладные пластины для установки режущих пластин SNMX 2512 и SNMX 1507 с вогнутой передней поверхностью

СНЯТИЕ ГРАТА

ИНСТРУМЕНТ ДЛЯ СНЯТИЯ ГРАТА СО СВАРНЫХ ШВОВ

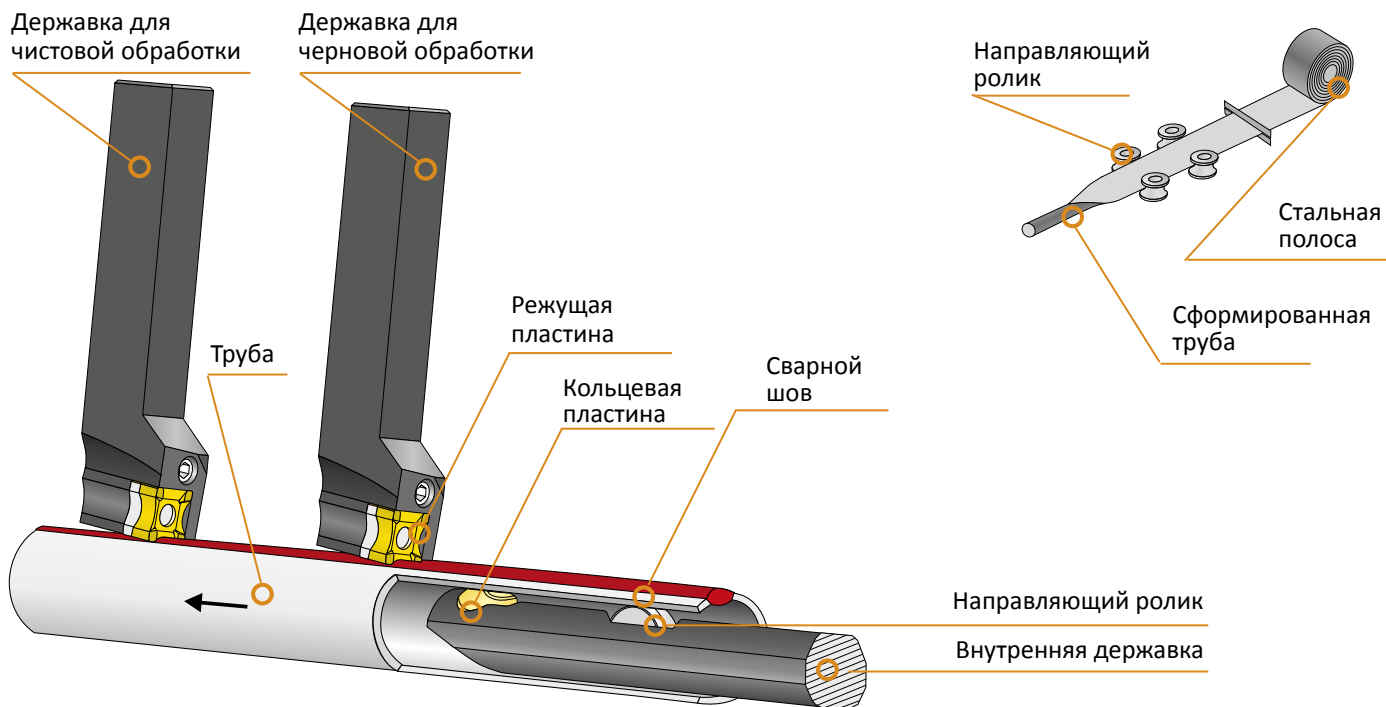

КАКИЕ ПЛАСТИНЫ СЛЕДУЕТ ИСПОЛЬЗОВАТЬ ДЛЯ ТРУБЫ ОПРЕДЕЛЕННОГО ДИАМЕТРА?

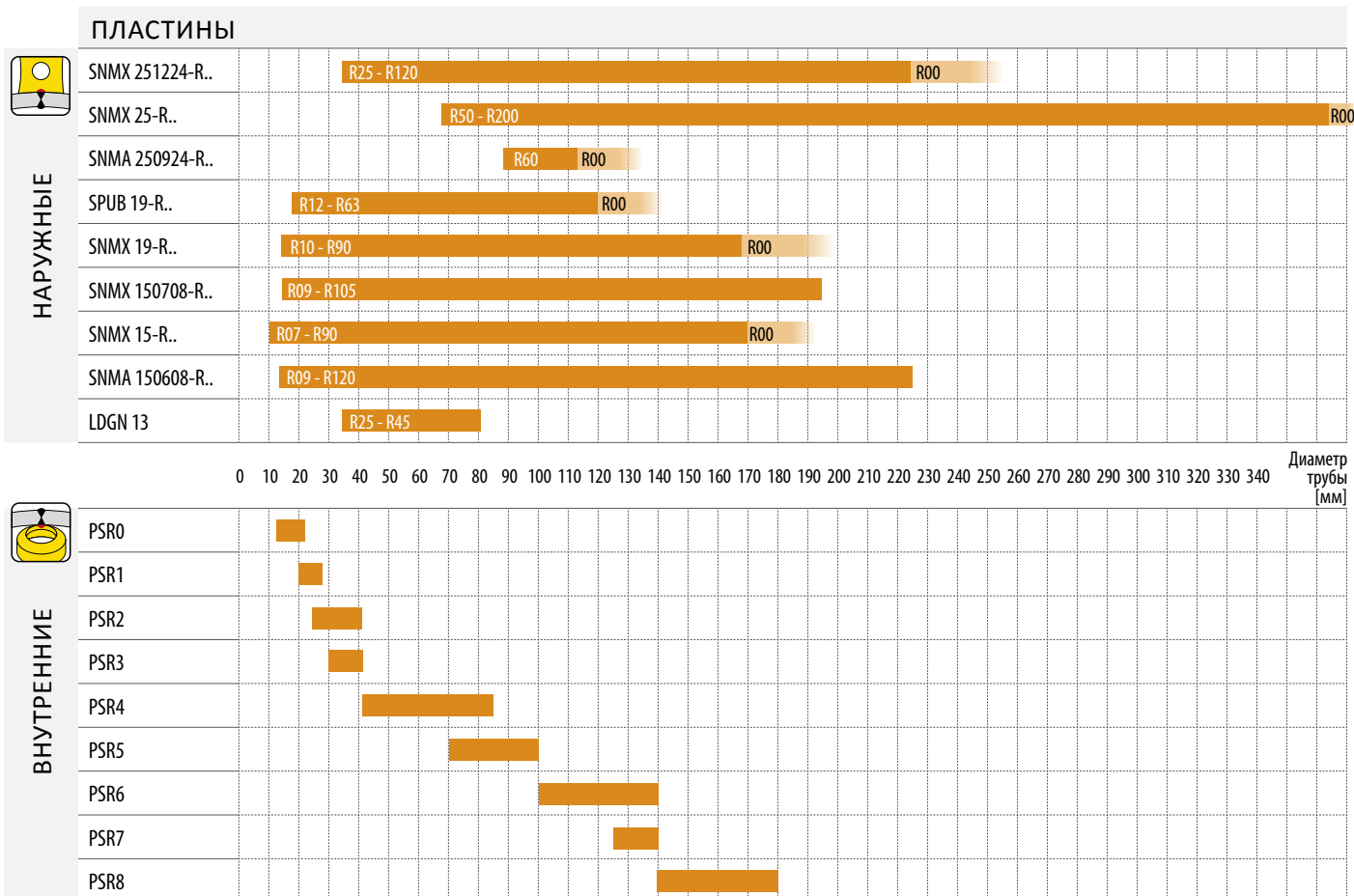

1 PXFN(RL)

2 P M

3 P

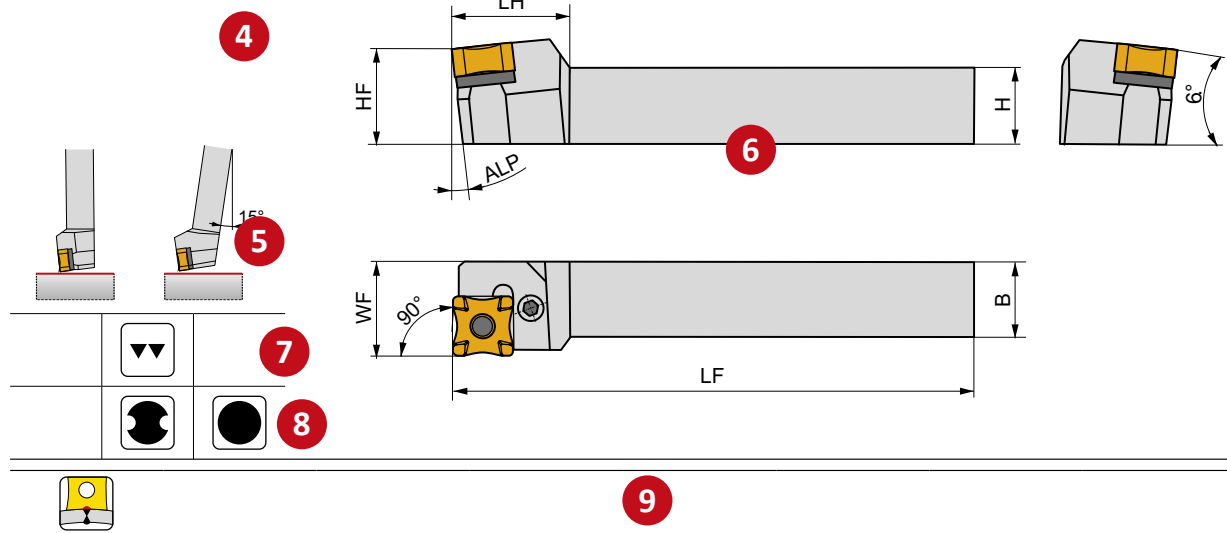

	H	B	HF	WF	OAL	LH	ALP	kg	CMX	PX	AT
	[mm]	[mm]		[mm]	[mm]	[mm]	[°]				
PXFNR/L 2525 R 15	25	25	25	25	200	40	6	1,05	GI185	PX 40	AT009
PXFNR/L 2525	25	25	25	25	250	45	6	1,2	GI186	PX 50	AT010
PXFNR/L 3232 S 25	32	32	40	40	250	50	6	2,2	GI199	PX 60	AT010

CMX	16
GI185	SNMX 15-R..
GI186	SNMX 19-R..
GI199	SNMX 25-R..

PX	SNU	PU	17	MT	HXK
PX40	SNU 150310-R	PU 03	US 36	MT 07	HXK 4
PX50	SNU 190410-R	PU 05	US 38	MT 06	HXK 5
PX60	SNU 250424-R	PU 06	US 39	MT 08	HXK 5

AT	SNMX	18	SNU
AT009	SNMX 150708-R..		SNU 150410-CX
AT010	SNMX 251224-R..		SNU 250524-CX

- | | | |
|--|--|---|
| 1 Тип токарной державки | 7 Достигаемое качество обработанной поверхности | 13 Комплект совместимых СМП ²⁾ |
| 2 Группа обрабатываемости материала | 8 Характеристика условий обработки | 14 Комплект запасных частей ^{2), 3)} |
| 3 Система крепления пластин | 9 Пиктограммы технологических возможностей | 15 Комплект опциональных комплектующих ^{2), 3)} |
| 4 Изображение ¹⁾ | 10 Обозначение державки | 16 Типоразмер СМП комплекта |
| 5 Типовая схема обработки | 11 Основные размеры [мм] и углы | 17 Запасные части |
| 6 Эскиз | 12 Масса [кг] | 18 Опциональные комплектующие |

¹⁾ Державки изображаются в правом исполнении (R)







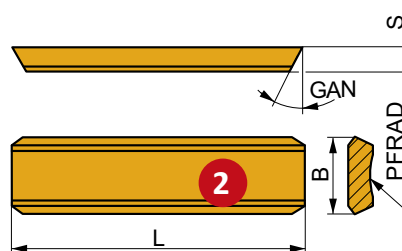

²⁾ Номер группы пластин и запасных частей используется только в этом каталоге и не может быть использован для заказа.

³⁾ Запасные части и опциональные комплектующие изображены схематично. В некоторых случаях добавлена информация о крутящем моменте затяжки, длине и размере резьбы винтов.

1 LDGN

	L	3	B	GAN
13,05	60,00	5,00	15,00	30°





		ISO		P	M	K	N	S	H	PFRAD	
		LDGN 130560-R25	6640	■	■					25	34-45
		LDGN 130560-R30	6640	■	■					30	41-54
		LDGN 130560-R35	6640	■	■					35	48-63
		LDGN 130560-R40	6640	■	■					9	54-63
		LDGN 130560-R45	6640	■	■						10

1	Тип пластины
2	Эскиз пластины
3	Таблица размеров пластин [мм]
4	Пиктограммы - особенности, тип режущей кромки и изображение пластины
5	Профиль главной режущей кромки







6	Маркировка пластины по ISO
7	Марка твердого сплава
8	Область применения пластины по обрабатываемым материалам
9	Радиус кривизны пластины
10	Диаметр трубы

ПИКТОГРАММЫ И СИМВОЛЫ

 Основное применение  Отсутствие пиктограммы - инструмент не рекомендуется для данной операции или группы материала

 Возможное применение

Пиктограммы - державки

Основные особенности инструмента	
	Группа обрабатываемого материала
	Получистовая обработка - хорошее качество поверхности
	Нестабильные условия обработки
	Крайне нестабильные условия обработки
	Наружная обработка
	Внутренняя обработка

Пиктограммы - пластины

Особенности	
	Универсальное применение
	Для материалов, образующих сливную стружку
	Скругленная режущая кромка
Условия применения	
	Основное применение
	Возможное применение
	Стабильные условия обработки
	Нестабильные условия обработки
	Крайне нестабильные условия обработки

СМЕННЫЕ ПЛАСТИНЫ

SNMX 15-R

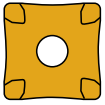

10

SNMX 19-R

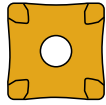

11

SNMX 25-R

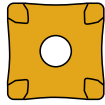

12

SNMX 1507-R

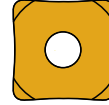

12

SNMX 2512-R

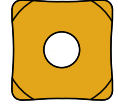

13

SNMA 1506-R



14

SNMA 2509-R



15

SPUB 19-R



15

LDGN



16

PSR



16-17

ДЕРЖАВКИ

PFXN(RL) EXT

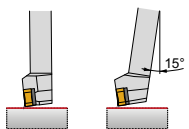

SN..



15

19

25



25x25
32x32

18

10-15

XLCD(N) EXT

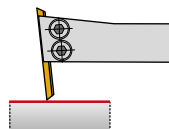

LDGN



13



25x25

19

16

SNMX 15-R



	L	IC	D1	S
SNMX 15	15,875	15,875	5,16	8,15

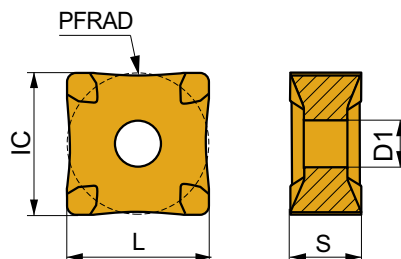

i	↖	ISO		<table border="1"> <tr> <th>P</th> <th>M</th> <th>K</th> <th>N</th> <th>S</th> <th>H</th> </tr> </table>						P	M	K	N	S	H	PFRAD	
				P	M	K	N	S	H								
SNMX 15-R00	T9335	■	■					0	0-0								
SNMX 15-R07	T9335	■	■					7	10-13								
	6640	■	■					7	10-12								
SNMX 15-R09	T9335	■	■					9	12-16								
	6640	■	■					9	12-16								
SNMX 15-R11	T9335	■	■					11	15-19								
	6640	■	■					11	15-19								
SNMX 15-R13	T9335	■	■					13	18-23								
	6640	■	■					13	18-23								
SNMX 15-R15	T9335	■	■					15	20-27								
	6640	■	■					15	20-27								
SNMX 15-R18	T9335	■	■					18	24-32								
	6640	■	■					18	24-32								
SNMX 15-R20	T9335	■	■					20	27-36								
	6640	■	■					20	27-36								
SNMX 15-R22	T9335	■	■					22	30-39								
	6640	■	■					22	30-39								
SNMX 15-R25	T9335	■	■					25	34-45								
	6640	■	■					25	34-45								
SNMX 15-R27	T9335	■	■					27	37-48								
	6640	■	■					27	37-48								
SNMX 15-R30	T9335	■	■					30	41-54								
	6640	■	■					30	41-54								
SNMX 15-R35	T9335	■	■					35	48-63								
	6640	■	■					35	48-63								
SNMX 15-R40	T9335	■	■					40	54-72								
	6640	■	■					40	54-72								
SNMX 15-R45	T9335	■	■					45	61-81								
	6640	■	■					45	61-81								
SNMX 15-R50	T9335	■	■					50	68-90								
	6640	■	■					50	68-90								
SNMX 15-R60	T9335	■	■					60	89-112								
	6640	■	■					60	89-112								
SNMX 15-R90	6640	■	■					90	133-169								

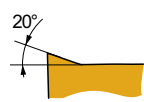

SNMX 19-R



	L	IC	D1	S
SNMX 19	19,050	19,050	7,95	8,15

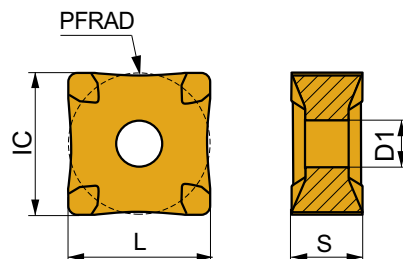

i	ISO	T9335	P	M	K	N	S	H	PFRAD	ODW
	SNMX 19-R00	T9335	■	■					0	0-0
	SNMX 19-R10	T9335	■	■					10	14-18
		6640	■	■					10	14-18
	SNMX 19-R12	T9335	■	■					12	16-21
		6640	■	■					12	16-21
	SNMX 19-R15	T9335	■	■					15	20-27
		6640	■	■					15	20-27
	SNMX 19-R18	T9335	■	■					18	24-32
	SNMX 19-R20	T9335	■	■					20	27-36
		6640	■	■					20	27-36
	SNMX 19-R22	T9335	■	■					22	30-39
	SNMX 19-R25	T9335	■	■					25	34-45
		6640	■	■					25	34-45
	SNMX 19-R30	T9335	■	■					30	41-54
		6640	■	■					30	41-54
	SNMX 19-R35	T9335	■	■					35	48-63
		6640	■	■					35	48-63
	SNMX 19-R40	T9335	■	■					40	54-72
		6640	■	■					40	54-72
	SNMX 19-R45	T9335	■	■					45	61-81
		6640	■	■					45	61-81
	SNMX 19-R50	T9335	■	■					50	68-90
		6640	■	■					50	68-90
	SNMX 19-R55	T9335	■	■					55	81-103
		6640	■	■					55	81-103
	SNMX 19-R60	T9335	■	■					60	89-112
		6640	■	■					60	89-112
	SNMX 19-R65	T9335	■	■					65	96-122
		6640	■	■					65	96-122
	SNMX 19-R75	T9335	■	■					75	111-141
	SNMX 19-R80	T9335	■	■					80	118-150
		6640	■	■					80	118-150
	SNMX 19-R85	T9335	■	■					85	126-159
	SNMX 19-R90	T9335	■	■					90	133-169
		6640	■	■					90	133-169

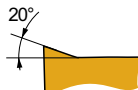

SNMX 25-R



	L	IC	D1	S
SNMX 25	25,400	25,400	9,12	12,20

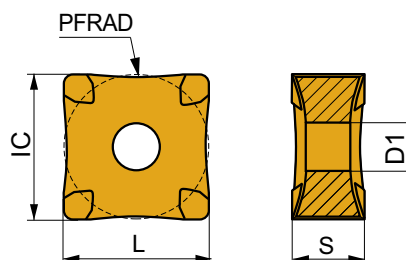

i	↖	ISO	[Texture]	P	M	K	N	S	H	PFRAD	[ODW]
		SNMX 25-R00	T9335	■	■					0	0-0
		SNMX 25-R50	T9335	■	■					50	68-90
		SNMX 25-R80	T9335	■	■					80	118-150
			6640	■	■					80	118-150
		SNMX 25-R100	T9335	■	■					100	148-188
			6640	■	■					100	148-188
		SNMX 25-R120	T9335	■	■					120	178-225
			6640	■	■					120	178-225
		SNMX 25-R140	T9335	■	■					140	207-263
			6640	■	■					140	207-263
		SNMX 25-R160	T9335	■	■					160	237-300
			6640	■	■					160	237-300
	SNMX 25-R180	T9335	■	■					180	266-338	
	SNMX 25-R200	T9335	■	■					200	296-376	
		6640	■	■					200	296-376	







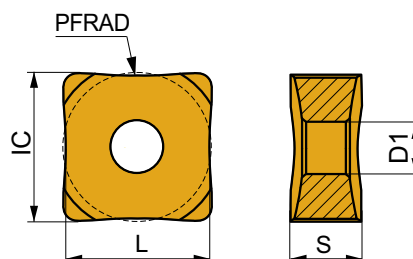

SNMX 1507-R



	L	IC	D1	S
1507	15,875	15,875	5,16	7,75



i	↖	ISO	[Texture]	P	M	K	N	S	H	PFRAD	[ODW]
		SNMX 150708-R09	6640	■	■					9	13-16
		SNMX 150708-R11	6640	■	■					11	16-19
		SNMX 150708-R13	6640	■	■					13	19-23
		SNMX 150708-R15	6640	■	■					15	22-27
		SNMX 150708-R18	6640	■	■					18	26-32
		SNMX 150708-R20	6640	■	■					20	29-36
		SNMX 150708-R22	6640	■	■					22	32-39
		SNMX 150708-R25	6640	■	■					25	37-45
		SNMX 150708-R27	6640	■	■					27	39-48
		SNMX 150708-R30	6640	■	■					30	44-54
		SNMX 150708-R35	6640	■	■					35	51-63
		SNMX 150708-R40	6640	■	■					40	58-72
		SNMX 150708-R42	6640	■	■					42	61-75
		SNMX 150708-R45	6640	■	■					45	66-81

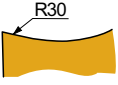





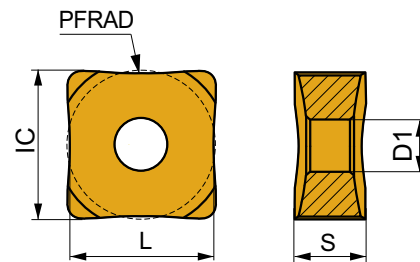

		ISO		P	M	K	N	S	H	PFRAD	
   		SNMX 150708-R50	6640	■	■					50	73-93
		SNMX 150708-R60	6640	■	■					60	88-111
		SNMX 150708-R65	6640	■	■					65	95-120
		SNMX 150708-R70	6640	■	■					70	102-130
		SNMX 150708-R75	6640	■	■					75	110-139
		SNMX 150708-R80	6640	■	■					80	117-148
		SNMX 150708-R90	6640	■	■					90	131-167
		SNMX 150708-R100	6640	■	■					100	146-186
		SNMX 150708-R105	6640	■	■					105	153-195

SNMX 2512-R



	L	IC	D1	S
2512	25,400	25,400	9,17	12,00

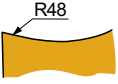

		ISO		P	M	K	N	S	H	PFRAD	
   		SNMX 251224-R00	T9335	■	■					0	0-0
		SNMX 251224-R25	T9335	■	■					25	34-45
		SNMX 251224-R30	T9335	■	■					30	41-54
		SNMX 251224-R35	T9335	■	■					35	48-63
		SNMX 251224-R40	T9335	■	■					40	54-72
		SNMX 251224-R55	T9335	■	■					55	81-103
		SNMX 251224-R80	T9335	■	■					80	118-150
		SNMX 251224-R100	T9335	■	■					100	148-188
		SNMX 251224-R120	T9335	■	■					120	178-225

SNMA 1506-R

PRAMET

	L	IC	D1	S
1506	15,875	15,875	5,16	6,35

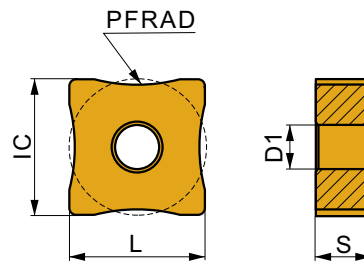

i	↖	ISO	6640	Material Groups						PFRAD	ODV
				P	M	K	N	S	H		
		SNMA 150608-R09	6640	■	■					9	13-16
		SNMA 150608-R11	6640	■	■					11	16-20
		SNMA 150608-R13	6640	■	■					13	19-24
		SNMA 150608-R15	6640	■	■					15	22-28
		SNMA 150608-R18	6640	■	■					18	27-33
		SNMA 150608-R20	6640	■	■					20	30-37
		SNMA 150608-R22	6640	■	■					22	33-41
		SNMA 150608-R25	6640	■	■					25	37-47
		SNMA 150608-R27	6640	■	■					27	40-50
		SNMA 150608-R30	6640	■	■					30	44-56
		SNMA 150608-R35	6640	■	■					35	52-65
		SNMA 150608-R40	6640	■	■					40	59-75
		SNMA 150608-R42	6640	■	■					42	62-78
		SNMA 150608-R45	6640	■	■					45	67-84
		SNMA 150608-R50	6640	■	■					50	74-94
		SNMA 150608-R60	6640	■	■					60	89-112
		SNMA 150608-R65	6640	■	■					65	96-122
		SNMA 150608-R70	6640	■	■					70	104-131
		SNMA 150608-R75	6640	■	■					75	111-141
		SNMA 150608-R80	6640	■	■					80	118-150
		SNMA 150608-R90	6640	■	■					90	133-169
		SNMA 150608-R105	6640	■	■					105	155-197
		SNMA 150608-R120	6640	■	■					120	178-225

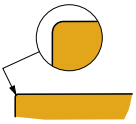

SNMA 2509-R



	L	IC	D1	S
2509	25,400	25,400	9,12	9,52

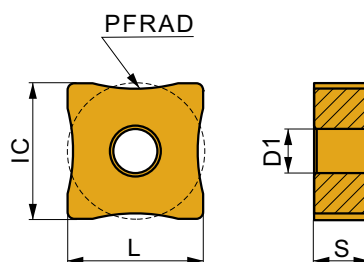

i	ISO	T9335	P	M	K	N	S	H	PFRAD	ODW
U		T9335	■	■					0	0-0
E		T9335	■	■					60	89-112

SPUB 19-R



	L	IC	D1	S
SPUB 19	19,050	19,050	5,15	4,75

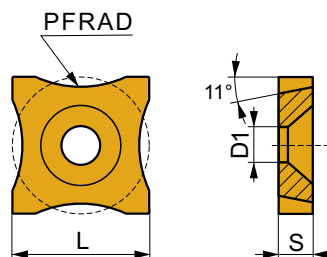

i	ISO	ANSI	T9335	P	M	K	N	S	H	PFRAD	ODW
U E		SPUB-63-M	T9335	■	■					0	0-0
			6640	■	■					0	0-0
		SPUB-63-B	T9335	■	■					12	18-22
			6640	■	■					12	18-22
		SPUB-63-C	T9335	■	■					15	22-28
			6640	■	■					15	22-28
		SPUB-63-D	T9335	■	■					20	29-37
			6640	■	■					20	29-37
		SPUB-63-E	T9335	■	■					25	37-47
			6640	■	■					25	37-47
		SPUB-63-F	T9335	■	■					30	45-57
			6640	■	■					30	45-57
		SPUB-63-G	T9335	■	■					40	60-76
			6640	■	■					40	60-76
		SPUB-63-H	T9335	■	■					50	75-95
			6640	■	■					50	75-95
		SPUB-63-I	T9335	■	■					63	95-120
			6640	■	■					63	95-120

* Пластина имеет задний угол 11° по всему контуру

LDGN



	L	S	B	GAN
13,05	60,00	5,00	15,00	30°

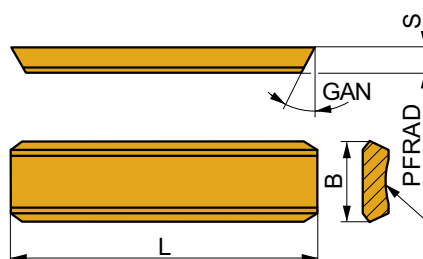



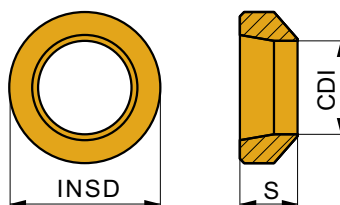

i	ISO	Material	P	M	K	N	S	H	PFRAD	ODW
	LDGN 130560-R25	6640	■	■					25	34-45
	LDGN 130560-R30	6640	■	■					30	41-54
	LDGN 130560-R35	6640	■	■					35	48-63
	LDGN 130560-R40	6640	■	■					40	54-72
	LDGN 130560-R45	6640	■	■					45	61-81

PSR



i	ISO	Material	P	M	K	N	S	H	INSD	CDI	S	PFRAD	IDW
	PSR0-R3.5	T9335	■	■					6,0	3,0	3,5	3,4	12-13,5
	PSR0-R4	T9335	■	■					6,0	3,5	3,5	4,0	12-14
	PSR0-R4.5	T9335	■	■					8,0	4,0	4,0	4,6	13,5-19
		5040	■	■					8,0	4,0	4,0	4,6	13,5-19
		S45	■	■					8,0	4,0	4,0	4,6	13,5-19
	PSR0/10-R4.5*	T9335	■	■					10,0	4,0	4,0	4,6	13,5-19
	PSR0-R5.5	T9335	■	■					8,0	5,0	4,0	5,7	16-20
		5040	■	■					8,0	5,0	4,0	5,7	16-20
		S45	■	■					10,0	6,0	4,5	6,8	17-21
	PSR0/10-R5.5*	T9335	■	■					10,0	5,0	4,0	5,7	16-20
	PSR0-R6	T9335	■	■					10,0	5,5	4,5	6,3	17-20
		5040	■	■					10,0	5,5	4,5	6,3	17-20
	PSR0-R6.5	T9335	■	■					10,0	6,0	4,5	6,8	17-21
		5040	■	■					10,0	6,0	4,5	6,8	17-21
		S45	■	■					10,0	6,0	4,5	6,8	17-21
PSR0-5-R6.5*	T9335	■	■					10,0	6,0	5,0	6,8	17-22	
PSR0-R7	T9335	■	■					10,0	6,5	4,5	7,4	17-22	
	S45	■	■					10,0	6,5	4,5	7,4	20-22	

i	ISO		P	M	K	N	S	H	INSD	CDI	S	PFRAD	
	PSR1-R7	T9335	■	■					13,0	6,0	5,0	6,8	20-22
		5040	■	■					13,0	6,0	5,0	6,8	20-22
		S45	■	■					13,0	6,0	5,0	6,8	20-22
	PSR1-R7.5	T9335	■	■					13,0	6,8	5,0	7,8	21-23
		PSR1-R8	T9335	■	■				13,0	7,0	5,0	8,0	22-24
			5040	■	■				13,0	7,0	5,0	8,0	22-24
	S45		■	■				13,0	7,0	5,0	8,0	22-24	
	PSR1-R9	T9335	■	■					13,0	8,0	5,0	9,1	24-26
		5040	■	■					13,0	8,0	5,0	9,1	25-28
S45		■	■					13,0	8,0	5,0	9,1	25-28	
PSR1-R10	T9335	■	■					13,0	9,0	5,0	10,2	25-28	
	5040	■	■					13,0	9,0	5,0	10,2	25-28	
	S45	■	■					13,0	9,0	5,0	10,2	25-28	
	PSR2-R9	T9335	■	■					19,0	8,0	8,0	9,1	24-26
		PSR2-R10	T9335	■	■				19,0	9,0	8,0	10,2	26-28
			5040	■	■				19,0	9,0	8,0	10,2	26-28
	S45		■	■				19,0	9,0	8,0	10,2	26-28	
	PSR2-R11	T9335	■	■					19,0	10,0	8,0	11,4	28-30
		5040	■	■					19,0	10,0	8,0	11,4	28-30
		S45	■	■					19,0	10,0	8,0	11,4	28-30
	PSR2-R12	T9335	■	■					19,0	11,0	8,0	12,5	30-34
		5040	■	■					19,0	11,0	8,0	12,5	30-34
S45		■	■					19,0	11,0	8,0	12,5	30-34	
PSR2-R13	T9335	■	■					19,0	11,9	8,0	13,5	31-35	
	PSR2-R14	T9335	■	■				19,0	12,5	8,0	14,3	32-41	
		PSR3-R12	T9335	■	■				22,0	11,0	10,0	12,5	30-34
PSR3-R14			T9335	■	■				22,0	12,0	10,0	13,7	32-41
	5040		■	■				22,0	12,0	10,0	13,7	32-41	
	S45	■	■				22,0	12,0	10,0	13,7	32-41		
PSR3-R17	T9335	■	■					22,0	15,0	10,0	17,1	36-41	
	5040	■	■					22,0	15,0	10,0	17,1	36-41	
	S45	■	■					22,0	15,0	10,0	17,1	36-41	
PSR4-R20	T9335	■	■					30,0	17,0	12,0	19,4	41-50	
	PSR4-R23	T9335	■	■				30,0	20,0	12,0	22,8	48-57	
		5040	■	■				30,0	20,0	12,0	22,8	48-57	
S45		■	■				30,0	20,0	12,0	22,8	48-57		
PSR5-R25	T9335	■	■					35,0	22,0	12,0	25,1	70-85	
	5040	■	■					35,0	22,0	12,0	25,1	70-85	
	S45	■	■					35,0	22,0	12,0	25,1	70-85	
PSR5-R28	T9335	■	■					35,0	25,0	12,0	28,5	85-100	
	5040	■	■					35,0	25,0	12,0	28,5	85-100	
	S45	■	■					35,0	25,0	12,0	28,5	85-100	
PSR6-R34	T9335	■	■					45,0	30,0	15,0	34,2	100-130	
	5040	■	■					45,0	30,0	15,0	34,2	100-130	
	S45	■	■					45,0	30,0	15,0	34,2	100-130	
PSR7-R39	T9335	■	■					50,0	35,0	15,0	39,5	125-140	
	S45	■	■					50,0	35,0	15,0	39,5	125-140	
PSR8-R46	T9335	■	■					55,0	40,0	18,0	45,6	140-180	
	5040	■	■					55,0	40,0	18,0	45,6	140-180	

* нестандартные размеры

* модификация INSD , S

PXFN(RL)



PRAMET

P

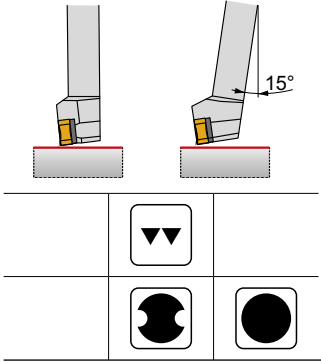
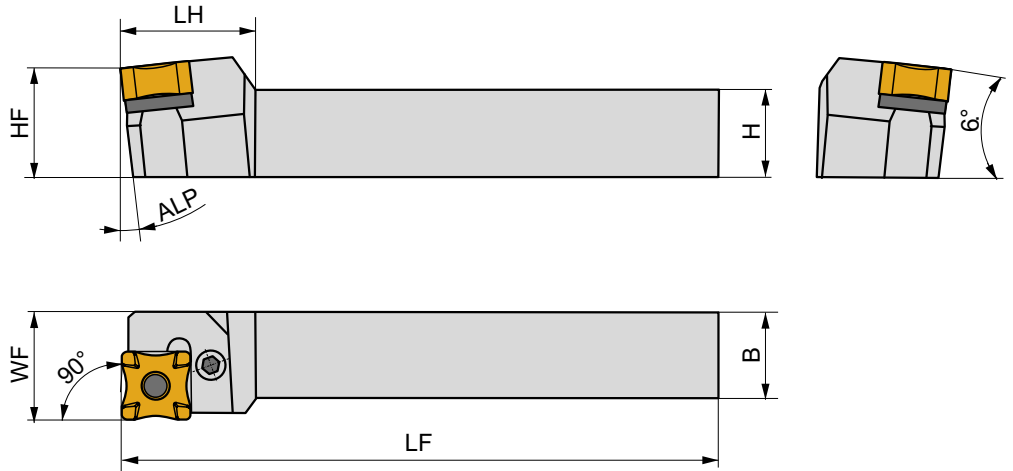

	H	B	HF	WF	LF	LH	ALP	kg			
	[mm]	[mm]		[mm]	[mm]	[mm]	[°]				
PXFNR/L 2525 R 15	25	25	25	25	200	40	6	1,05	G185	PX 40	AT009
PXFNR/L 2525 S 19	25	25	25	25	250	45	6	1,3	G186	PX 50	-
PXFNR/L 3232 S 25	32	32	40	40	250	50	6	2,2	G199	PX 60	AT010
PXFNR/L 2525 R 15/15	25	25	25	25	200	40	20	1,05	G185	PX 40	AT009
PXFNR/L 2525 S 19/15	25	25	25	25	250	50	20	1,3	G186	PX 50	-

G185	SNMX 15-R..
G186	SNMX 19-R..
G199	SNMX 25-R..

PX40	SNU 150310-R	PU 03	US 36	6,0	M8x1	26	NT 05	MT 07	HXK 4
PX50	SNU 190410-R	PU 05	US 38	8,0	M10x1	29	NT 06	MT 06	HXK 5
PX60	SNU 250424-R	PU 06	US 47	8,0	M12x1	36	NT 08	MT 08	HXK 5

AT009	SNMX 150708-R..	SNU 150410-CX
AT010	SNMX 251224-R..	SNU 250524-CX

XLCDN



PRAMET

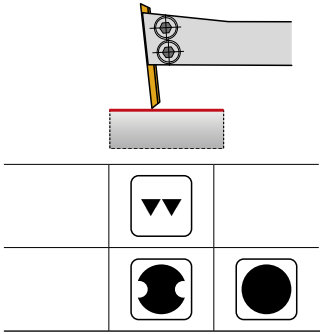
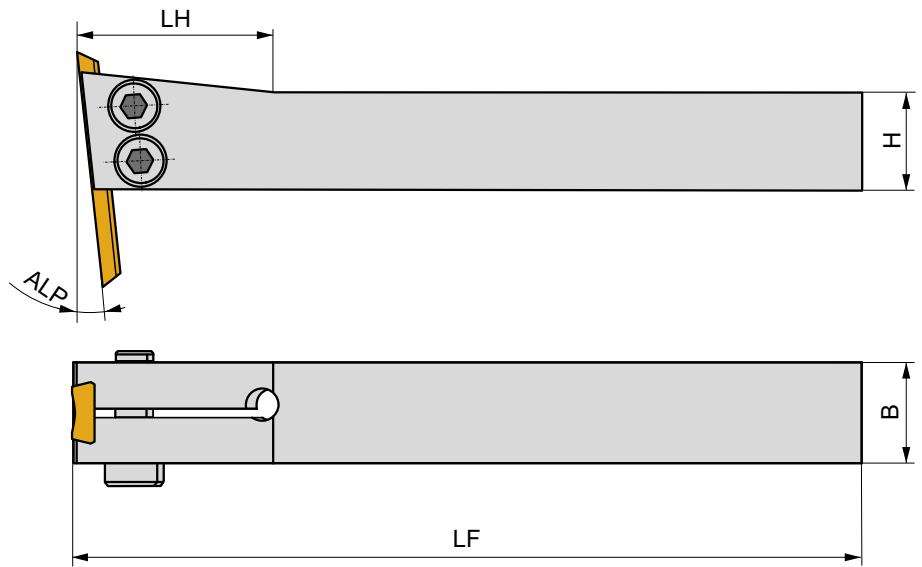

	H	B	LF	LH	ALP	kg	G1187	PX10
	[mm]	[mm]	[mm]	[mm]	[°]			
XLCDN 2525 R 15	25	25	200	50	6	1,10	G1187	PX10

G1187	LDGN 130560...
-------	----------------

PX10	HS 0825	M8	25	HKX 6
------	---------	----	----	-------

ТЕХНИЧЕСКАЯ ЧАСТЬ

ТВЕРДЫЕ СПЛАВЫ ДЛЯ СНЯТИЯ ГРАТА

Марка твердого сплава	Область применения	Применение	Подача	Скорость резания	Устойчивость к неблагоприятным условиям обработки	Субстрат	Покрытие	Цвет	Преимущество использования СОЖ	Общая обработка	Обработка с высокой скоростью	Обработка с низкой скоростью
T9335	P20 - P45	■				FGM	MT-CVD	■	+++	✓	✓	
	M15 - M40	■										
6640	P20 - P45	■				H	MT-CVD	■	+++	✓		✓
	M15 - M40	■										
5040	P30 - P45	■				S	MT-CVD	■	++	✓		✓
	M30 - M40	□										
S45	P30 - P45	■				S	X	■	++			✓
	M30 - M40	□										

Субстрат		Покрытие	
H	Субстрат WC с Co	MT-CVD	Среднетемпературное покрытие, нанесенное методом химического осаждения из газовой фазы
FGM	Функционально-градиентный субстрат	X	Сплав без покрытия
S	Субстрат с кубическими карбидами		

PXFN(RL) — РАЗНЫЕ ДЕРЖАВКИ С УЧЕТОМ НАКЛОНА ГОЛОВКИ

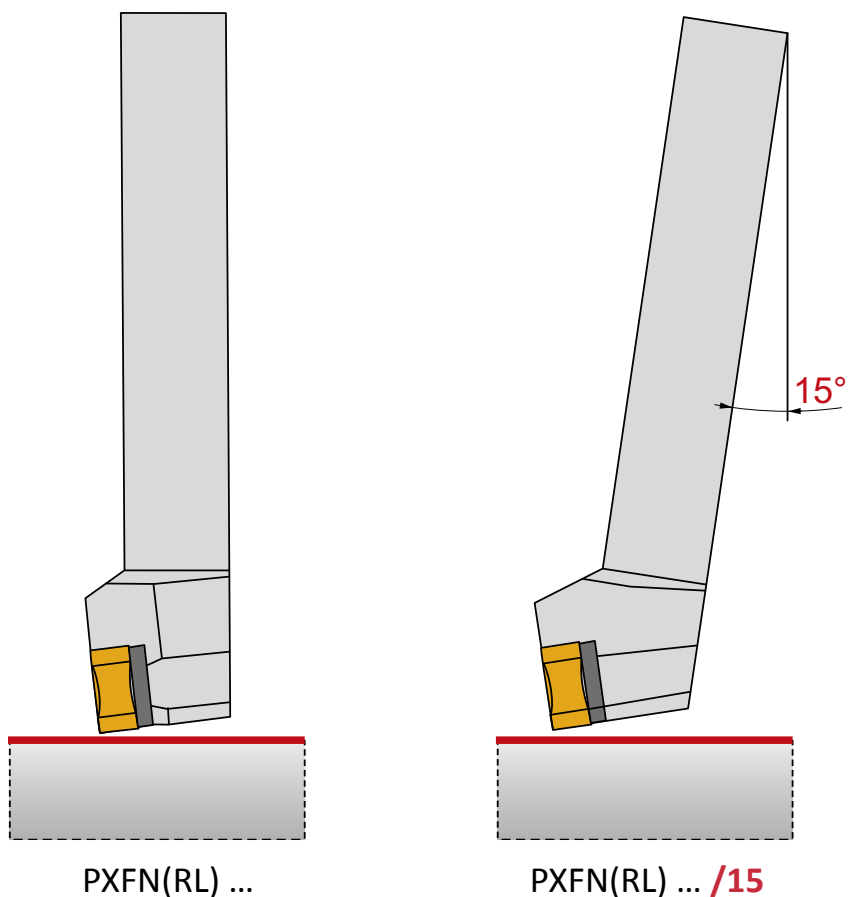

LDGN — ПЛАСТИНЫ ДЛЯ ПЕРЕТОЧКИ

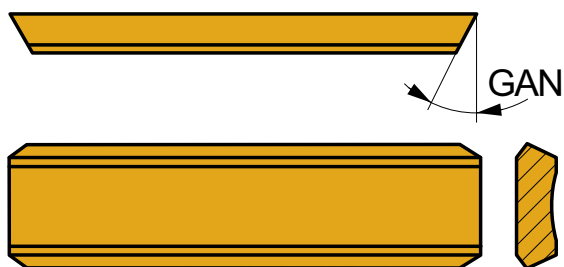









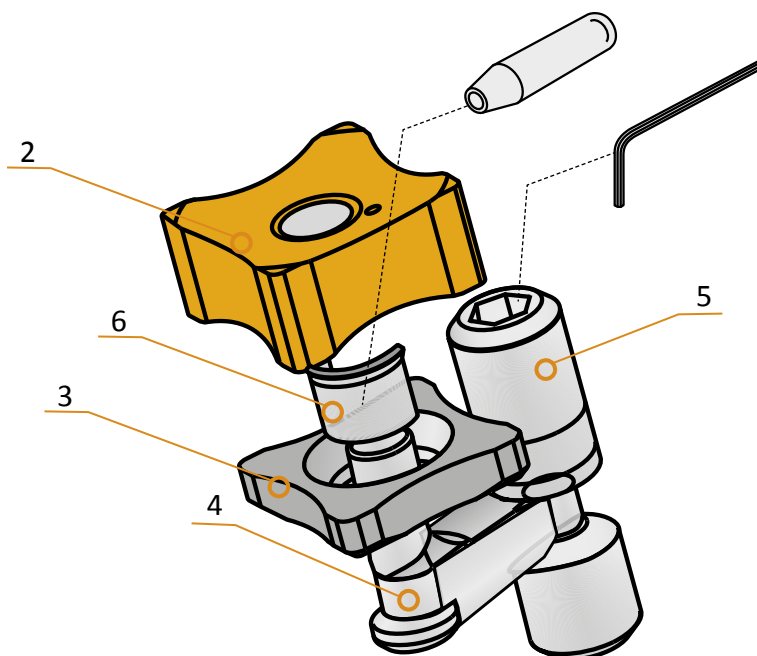











Пластины имеют длительный срок службы благодаря общей длине пластины (60 мм), которую можно несколько раз перетачивать до достижения минимальной длины 25 мм.

Передний угол можно легко изменить (сделав его более или менее положительным), заточив пластину для оптимизации процесса снятия грата.

Подходит для обработки сварного шва небольшого сечения.

PXFN(RL) — РАЗНЫЕ ЗАПЧАСТИ С УЧЕТОМ ТИПА ПЛАСТИНЫ



1	2	3	4	5	6	7	8
PXFNR/L 2525 R 15 PXFNR/L 2525 R 15/15	 SNMX 15-Rxx	 SNU 150310-R					
	 SNMX 150708-Rxx	 SNU 150410-CX	PU 03	US 36	NT 07	MT 07	HKX 4
PXFNR/L 2525 S 19 PXFNR/L 2525 S 19/15	 SNMX 19-Rxx	 SNU 190410-R	PU 05	US 38	NT 06	MT 06	HKX 5
	 SNMX 25-Rxx	 SNU 250424-R					
PXFNR/L 3232 S 25	 SNMX 251224-Rxx	 SNU 250524-CX	PU 06	US 47	NT 08	MT 08	HKX 5

КОЛЬЦЕВЫЕ ПЛАСТИНЫ ДЛЯ СНЯТИЯ ГРАТА - РАСЧЕТ РАБОЧЕГО РАДИУСА PFRAD

Рабочий радиус PFRAD образуется по внутреннему диаметру пластины DCI с учетом угла наклона

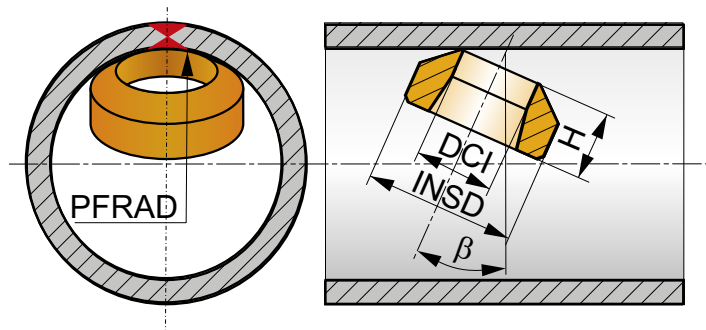

$$PFRAD = \frac{DCI}{2 \times \sin \beta}$$

DCI — внутренний диаметр кольцевой пластины

β — угол наклона кольцевой пластины

SIMPLY RELIABLE

Будучи профессионалом, вы можете оценить качество обработки, просто взглянув на стружку. Чистая и ровная форма стружки говорит сама за себя. Стружка - это точный индикатор стабильности технологического процесса, вот почему мы используем стружку как символ нашей надежности.

Argentina

T: 54 (11) 6777-6777
F: 54 (11) 4441-4467
info.ar@dormerpramet.com

Austria

T: +31 10 2080 240
info.at@dormerpramet.com

Belgium & Luxembourg

T: +32 3 440 59 01
info.be@dormerpramet.com

Brazil

T: +55 11 5660 3000
info.br@dormerpramet.com

Canada

T: (888) 336 7637
En Français: (888) 368 8457
F: (905) 542 7000
cs.canada@dormerpramet.com

China

T: +86 21 2416 0508
info.cn@dormerpramet.com

Croatia

T: +385 98 407 489
info.hr@dormerpramet.com

Czech Republic

T: +420 583 381 111
F: +420 583 215 401
info.cz@dormerpramet.com

Denmark

T: 808 82106
info.se@dormerpramet.com

Finland

T: 0205 44 7003
info.fi@dormerpramet.com

France

T: +33 (0)2 47 62 57 01
F: +33 (0)2 47 62 52 00
info.fr@dormerpramet.com

Germany

T: +49 9131 933 08 70
F: +49 9131 933 08 742
info.de@dormerpramet.com

Hungary

T: +36-96 / 522-846
F: +36-96 / 522-847
info.hu@dormerpramet.com

India

T: +91 11 4601 5686
info.in@dormerpramet.com

Italy

T: +39 02 30 70 54 44
info.it@dormerpramet.com

Kazakhstan

T: +7 771 305 11 45
info.kz@dormerpramet.com

Mexico

T: +52 (555) 7293981
F: +52 (555) 7293981
cs.mexico@dormerpramet.com

Netherlands

T: +31 10 2080 240
info.nl@dormerpramet.com

Norway

T: 800 10 113
info.se@dormerpramet.com

Poland

T: +48 32 78-15-890
F: +48 32 78-60-406
info.pl@dormerpramet.com

Portugal

T: +351 21 424 54 21
info.pt@dormerpramet.com

Romania

T: +4(0)730 015 885
info.ro@dormerpramet.com

Russia

T: +7 (495) 775 10 28
Ф: +7 (499) 763 38 90
info.ru@dormerpramet.com

Slovakia

T: +421 (41) 764 54 60
F: +421 (41) 763 74 49
info.sk@dormerpramet.com

Slovenia

T: +385 98 407 489
info.si@dormerpramet.com

Spain

T: +34 935717722
info.es@dormerpramet.com

Sweden

responsible for Iceland
T: +46 35 16 52 96
info.se@dormerpramet.com

Switzerland

T: +31 10 2080 240
info.ch@dormerpramet.com

Turkey

T: +90 533 212 45 47
info.tr@dormerpramet.com

Ukraine

T: +38 056 736 30 21
F: +38 067 220 97 48
info.ua@dormerpramet.com

United Kingdom

responsible for Ireland
T: 0870 850 4466
F: 0870 850 8866
info.uk@dormerpramet.com

United States of America

T: (800) 877-3745
F: (847) 783-5760
cs@dormerpramet.com

Other countries

South America

T: +55 11 5660 3000
info.br@dormerpramet.com

Adria

T: +420 583 381 527
F: +420 583 381 401
info.rcee@dormerpramet.com

Rest of the World

Dormer Pramet International UK
T: +44 1246 571338
F: +44 1246 571339
info.int@dormerpramet.com

Dormer Pramet International CZ

T: +420 583 381 520
F: +420 583 215 401
info.int.cz@dormerpramet.com

PRA-BRO-SCARFING-2020-RU